



Converter Accessory Corporation
www.converteraccessory.com



Core Locking / Holding Systems
www.cor-lok.com



CAC's COR-LOK air shafts and chucks are manufactured under US Patent number 3825167, 3917187, 3937412, 4124173

COR-LOK® Air Shafts B2 series with Schrader inflating valve



Unique Air Shaft for Unwinding and Rewinding

COR-LOK air shafts are different. Their unique design provides high-torque core locking with zero core damage. COR-LOK B2 series air shafts utilize inflating tube engineered to fit the COR-LOK spiral internal housing. Inflating the air shafts with pressurized air will actuate COR-LOK's interlocking segments to engage the core and lock it in place. These interlocking segments expand evenly around the circumference and across the width of the core, insuring even torque distribution in the core's inside diameter. This means your cores will not slip and will not distort during the unwind / rewind process.

Standard air shafts are supplied with thru bores, regardless of length (see COR-LOK air shaft dimensions, on opposite side). They may be mounted to any thru bar / shaft; locked in place with CAC's unique split busing design. Custom designs are available with thru shafts or mounted journals. Standard air shafts may be used in cantilevered and dual support applications.

- **Lightweight** - easy to use
- Interlocking segment design is easy to slide in and out of cores for fast roll changes
- High torque output to ensure your cores stay locked - **no core slipping**
- Interlocking segment design insures zero core damage
- Engineered inflating tube (bladderless)
- **Built to last!**
- **Made in the USA!**
- **15 Minute** maintenance
- 1" - 18" Diameter cores
- 3" - 120" Roll or core width
- Aluminum (standard), steel, stainless steel and carbon fiber construction
- Thru bore design (standard)
- **Standard designs**
- Custom designs to fit your machine
- Combine with CAC's unwind and rewind modules for a complete engineered solution



Inside CAC's COR-LOK® Air Shafts B2 Series with Schrader inflating valve

Core Locking / Holding Systems
www.cor-lok.com

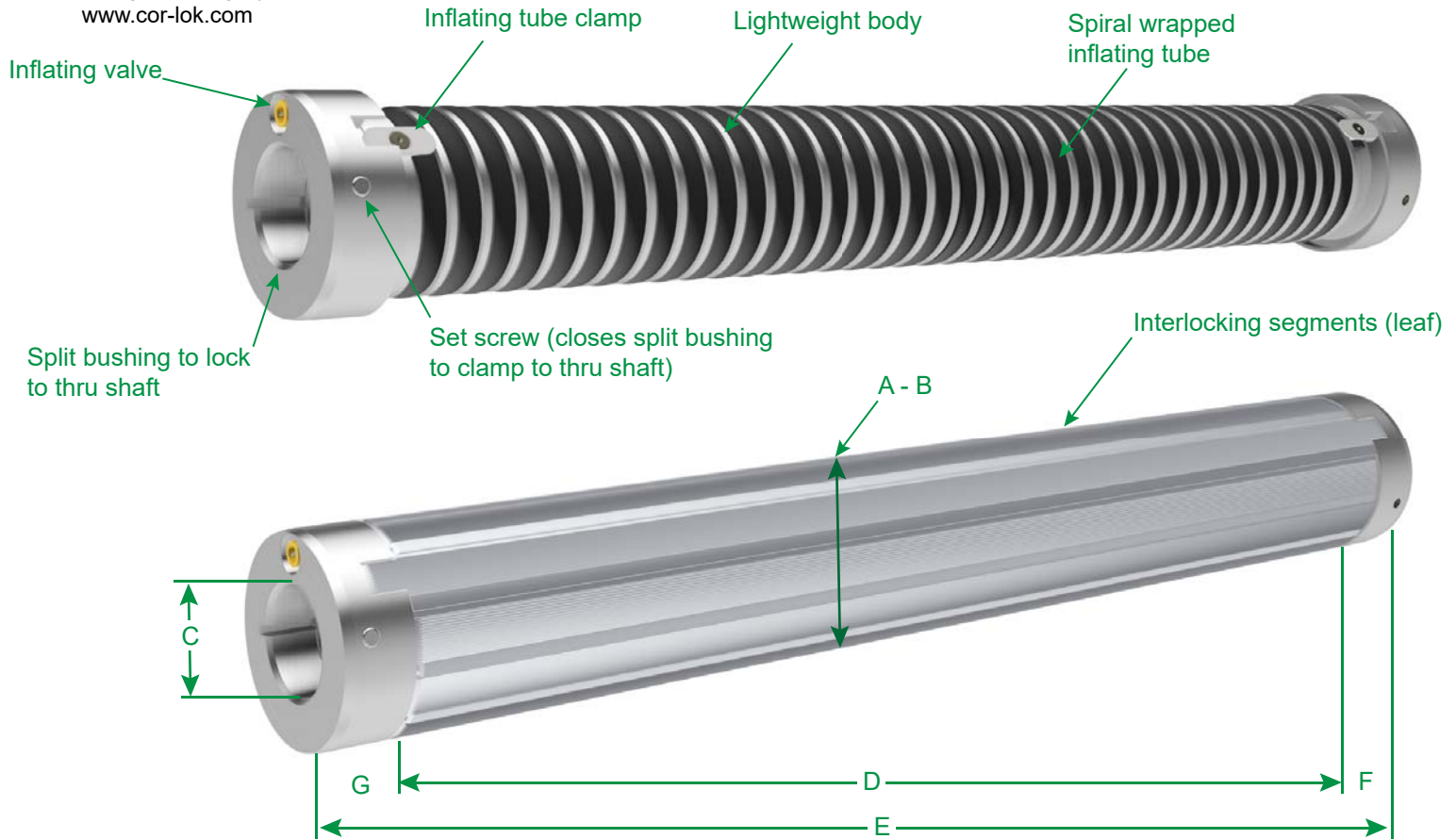

	A	B	C	D	E	F	G
Core size	Deflated Diameter	Inflated Diameter	Bore Range	Expanding Length	Overall length	End cap, plain end	End cap, valve end
2	1-31/32	2-3/32	up to 3/4	3-72	5-74	1	1
3	2-15/16	3-1/8	up to 1-3/4	3-120	5-120	1	1
4	3-15/16	4-3/16	up to 2-1/2	3-120	5-120	1	1
5	4-15/16	5-3/16	up to 3	3-120	5-120	1	1
6	5-15/16	6-3/16	up to 4	3-120	5-120	1	1
6 3/4	6-11/16	6-7/8	up to 4	3-120	5-120	1	1
7	6-15/16	7-3/16	up to 5	3-120	5-120	1	1
8	7-15/16	8-3/16	up to 6	3-120	5-120	1	1
9	8-15/16	9-3/16	up to 7	3-120	5-120	1	1
10	9-15/16	10-3/16	up to 8	3-120	5-120	1	1
11	10-15/16	11-3/16	up to 9	3-120	5-120	1	1
12	11-15/16	12-3/16	up to 10	3-120	5-120	1	1

Notes: 1) All dimensions in inches. Thru bores machined .010" - .015" oversized unless otherwise specified.
2) Custom and metric core sizes available, please contact us for more information.



Converter Accessory Corporation

201 Alpha Road, PO Box 188, Wind Gap, PA 18091-0188

www.converteraccessory.com
sales@converteraccessory.com

Phone: 800-433-2413
610-863-6008

Fax: 800-709-1007
610-863-7818